

# Conder<sup>®</sup> ASP

ACTIVATED SLUDGE PROCESS



WASTEWATER

**P** **CONDER**  
AQUA SOLUTIONS  
A PREMIER TECH AND EPS JOINT COMPANY

40  
years  
OF PASSION

THE PARTNER OF CHOICE

# Sewage treatment plant for residential and commercial projects

The Conder ASP Package Sewage Treatment Plant is the perfect solution for residential and commercial projects where mains drainage is unavailable. The plant will serve a population range from 6-25 and is fast becoming the industry's system of choice for reliability, ease and low installation costs.

Installed to treat wastewater with minimal impact on the environment, typical applications include single dwellings, small communities or developments, refurbishments and rural barn conversions.

# ASP

## Superior Technical Performance

The highly successful Conder ASP is designed and tested in accordance with BS EN12566-3:2005 the British Water Code of Practice for flows and loads as well as being CE marked. The standard range plants produce an effluent quality of better than 20mg/l BOD; 30mg/l SS; 20mg/l NH<sub>3</sub>.

# Complete Below Ground Installation

Conder Aqua Solutions has designed the ASP to have a minimal visual impact on site location. This includes complete below ground installation and a quiet and odourless operation which is assisted by a compact and innovative design.

## Low Costs

The Conder ASP offers superior technical performance at a competitive price, offering real value for money without compromising on quality. The on-going maintenance and running costs for the ASP are extremely low as well as having a better than average emptying frequency. This provides an overall competitively priced product for the duration of its lifetime.

## Quality, Adaptable Design

Conder Aqua Solutions has completed thousands of ASP installations across the globe and has pioneered the development of packaged sewage treatment plants. The Conder ASP consists of a state of the art GRP/HDPE durable, high strength structure and includes remote or integral blower housing.

The adaptable design offers the availability of an integral pumped system, deeper inverts (with supply of a standard extension kit), choice of pumped influent or effluent and is suitable for discharge to ground or watercourse (subject to relevant exemption, consent and licence).

## How the ASP Works

The Conder ASP treatment plant comprises of a single tank, within this tank there is an inner central bio-zone chamber and an outer settlement zone. Sewage enters and leaves the treatment plant through the following process:

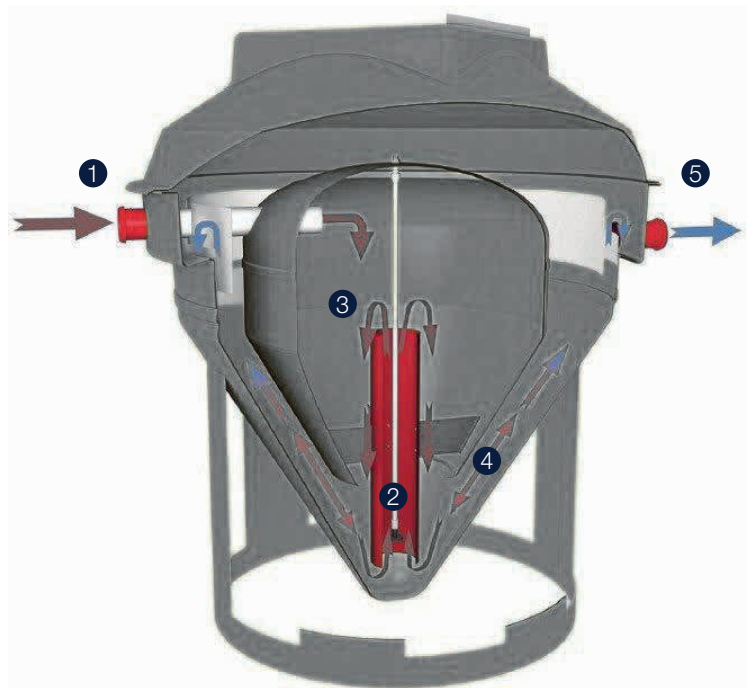

### ▶ Step 1

The plant accepts and treats the incoming sewage in the central bio-zone chamber, with use of the extended aeration principle.

### ▶ Step 2

A simple coarse bubble diffuser, housed in a draft tube, introduces the air that provides the oxygen to the bacteria, which then treats the sewage.

### ▶ Step 3

The bio-zone then retains the mixture of sewage and bacteria until the level of treatment has been achieved.

### ▶ Step 4

The treated effluent then enters the settlement zone where settlement takes place. The settled solids are drawn back towards the draft tube, with the diffuser in it, and are returned via the airlift principle to the bio-zone for further treatment.

### ▶ Step 5

The treated (final) effluent subsequently leaves the plant over a weir, at the outlet level, that extends around the circumference of the tank. The movement of the fluid through the whole system is by gravity displacement. The option for an integral final effluent pumped discharge is available.

# Specification

The table below can be used as a specification in choosing the correct Conder ASP for your project.

All applications should be specified to comply with the British Water Code of Practice for Flows and Loads. Further advice and assistance is available from our experienced internal and external sales teams. Site visits and assessments are recommended to ensure the correct equipment is proposed prior to installation.

Unit Measurements*		Conder ASP Range of Package Treatment Plants					
		ASP06	ASP08	ASP12	ASP16	ASP20	ASP25
Population Equivalent		06	08	12	16	20	25
Hydraulic Load	litres/day	1200	1600	2400	3200	4000	5000
Organic Load	gBOD <sub>5</sub> /day	360	480	720	960	1200	1500
Ammonia as Nitrogen	gNH <sub>3</sub> /day	48	64	96	128	160	200
Tank Diameter	mm A	1970	1970	1970	1970	1970	1970
Standard Inlet Invert to top of tank shell	mm B**	750	750	750	750	750	750
Inlet Invert to base	mm C	1500	1500	1800	1900	2000	2300
Outlet Invert to base	mm D	1400	1400	1700	1800	1900	2200
Overall Depth (excluding access cover height)	mm E**	2250	2250	2550	2650	2750	3050
Pipework Fitting	mm	110	110	110	110	110	110
Access Cover Size; Square	mm	750	750	750	750	750	750
Plant Weight	kg	230	230	260	300	360	440

\* To select a system with an integral final effluent pump add a 'P' suffix e.g. ASP06P.

\*\* Deeper installation depth can be accommodated with extension shafts.

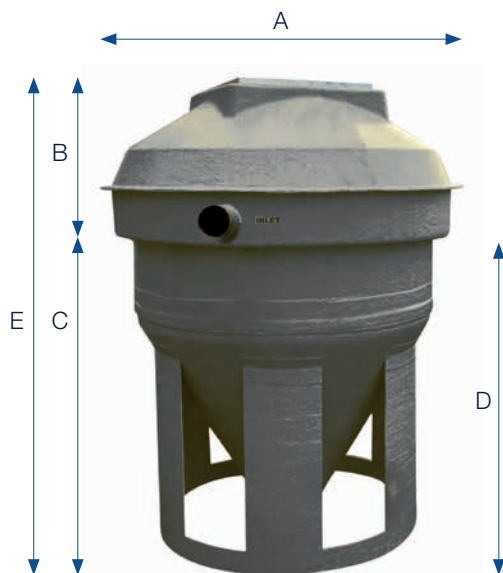

## Installation

The Conder ASP Package Sewage Treatment Plant requires a relatively low cost and easy installation process, typically using only a 200mm deep concrete base followed by a pea shingle or self compacting backfill.

Conder Aqua Solutions work closely with a nationwide network of installation partners and detailed installation guidelines are provided for each product.

All electrical work should be carried out in accordance with current regulations (for example NIC EIC/Building Regulations).

## Peripherals

### Extension Kit

Deeper inverts can be accommodated by means of an access extension kit which is available in a 1.0m length. These are designed to be cut to size on site and can also be retrofitted, again on site, taking away the worry of installing at incorrect levels.

### Package Pump Station

Inlet sewage and final effluent pump chambers are available in single or dual units, at varying inverts, and are designed to suit on site requirements. Again these can be retrofitted if required.

### Servicing

Through a nationwide network of British Water accredited service engineers, Conder Aqua Solutions offer a comprehensive range of services including commissioning and on-going service contracts. Please contact the Conder Aqua Solutions sales team for further information.

### Extended Warranty

All ASP products come with an automatic 12 month warranty. Extended 5 year warranties can be obtained for free by visiting our website and filling in a short Warranty Activation Form or completing the form supplied with the plant.